

Installation, commissioning and operating instructions

for stationary Fibre Nickel Cadmium Batteries grid | power FNC®



Foreword

Dear Customer,

Thank you very much for having decided in favour of a product bearing our brand name.

Please read this documentation carefully before working on the batteries or their components. It contains important information on safe and proper unpacking, storage, installation, commissioning and on operation and maintenance of grid | power FNC®-batteries.

Amendments to this documentation are subject to change without prior notice. Our products undergo continuous advanced development. As a result, there may be deviations between the illustrations given in this documentation and the purchased product. This installation manual is not covered by any change service.

Keep this documentation in such a manner that it is available immediately to all those who need to carry out work in connection with the battery system or its components.

HOPPECKE
Batterie Systeme GmbH
P.O. Box 11 80
D-59914 Brilon

Service-Hotline Germany:
0800 24677-32

Bontkirchener Straße 1
D-59929 Brilon-Hoppecke
Phone +49 (0)2963 61-1412
Fax +49 (0)2963 61-1452
Internet www.hoppecke.com
Email hbs@hoppecke.com

International Service-Hotline:
+49 (0)180 5229999

Installation, commissioning and operating instructions for stationary Fibre Nickel Cadmium Batteries grid | power FNC®

Type, Design, Print: PRIOTEX Medien GmbH, 59609 Anröchte

© 2021 HOPPECKE Batterien GmbH & Co. KG
P.O. Box 11 40
D-59914 Brilon

All rights reserved, even for patent and utility patent applications.
The distribution and duplication of this document and the use and disclosure of its contents are prohibited unless written permission is granted by HOPPECKE Batterien GmbH & Co. KG. Noncompliance will result in a claim for damages.

Table of Contents

1 Using this manual	6	8.1.5. Ventilation Requirements	23
1.1. Target group of this document.....	6	8.2. Installing the Battery System	24
1.2. Means of Representation	6	8.2.1. Preliminary Work on Unfilled and Uncharged grid power FNC®-cells.....	24
1.3. Notation of Nominal Data.....	7	8.2.2. Equipping the Rack or Cabinet	25
1.4. Abbreviations and Definitions	7	8.2.3. Connecting the Battery System.....	25
2 Safety	8	8.2.4. Labelling the Battery System	27
2.1. General Safety Instructions.....	8	9 Commissioning	27
2.2. Personal Protective Equipment.....	9	9.1. Charging Procedures for the Initial Commissioning	28
2.3. Specific Safety Instructions for grid power FNC®-Battery Systems	9	9.1.1. Charging with Constant Current.....	28
2.3.1. Safety Instructions on Handling with Electrolyte	9	9.1.2. Charging with Constant Current and Constant Voltage (CCCV)	29
2.3.2. Safety Instructions on Charging the Battery System.....	10	9.2. Commissioning of Unfilled and Uncharged (UU) and Filled and uncharged (FU) grid power FNC®-cells.....	30
2.3.3. Protection against dangerous body contact currents	10	9.3. Commissioning Filled and Charged (FC) FNC®-cells.....	31
2.3.4. Special hazards in the event of fire.....	11	9.4. Capacity Testing of Batteries According to DIN IEC 60623.....	32
3 Intended/Unintended use	11	10 Maintenance	32
3.1. Intended Use	11	10.1. Checking for Cleanliness and Condition of the Battery System	33
3.2. Unintended Use.....	11	10.2. Checking the Electrolyte Levels	34
4 Directives, Legislation and Standards	12	10.3. Measuring the Charging Voltage.....	36
5 Product description	12	10.4. Testing the Insulation Resistance.....	36
5.1. grid power FNC®-cell	12	10.5. Cleaning	37
5.2. Cell Plugs for Different Use Cases	14	10.6. Fill up the Electrolyte Level with Distilled Water.....	37
5.3. Operation Modes (see also IEC 62485-2)	14	10.7. Reconditioning.....	39
5.3.1. Standby parallel operation	14	11 Troubleshooting	42
5.3.2. Buffer operation	15	11.1. Over Consumption of Distilled Water.....	42
5.3.3. Switching mode (charge/discharge mode)	15	11.2. Dispersion of the Individual Cell Voltages.....	42
5.4. Battery Charging Characteristic	16	11.3. Available Battery Capacity is Low	42
5.5. Battery Capacity	17	11.4. Insulation Resistance is Low	43
6 Transport	18	11.5. Battery Voltage not Measurable	43
6.1. Surface Transport (Road/Rail) according to ADR/RID	18	12 Disassembly, Disposal and Recycling	43
6.2. Transport by sea according to the IMDG Code.....	19	13 Appendix	44
6.3. Air Freight.....	19	13.1. Commissioning Record	44
6.4. Checking the delivery.....	20	13.2. Maintenance Log.....	47
7 Storage	20	13.2.1. Six-monthly Maintenance Interval.....	48
7.1. Storage of Filled and Charged (FC) Cells.....	21	13.2.1.1. Visual Inspection and Checking Electrolyte Level	48
7.2. Storage of Unfilled and Uncharged (UU) and Filled and Uncharged (FU) grid power FNC®-cells	21	13.2.1.2. Measuring battery system voltage.....	49
8 Installation	22	13.2.2. Annual Maintenance Interval	50
8.1. Mounting a Rack or Cabinet.....	22	13.2.2.1. Cleaning the battery system	50
8.1.1. Before Mounting a Rack or Cab.....	22	13.2.2.2. Insulation testing.....	51
8.1.2. Checking the Scope of Delivery	22	13.2.2.3. Filling up distilled water	52
8.1.3. Mounting a Rack	23	13.2.3. Maintenance Interval every 5 years	52
8.1.4. Mounting a Cabinet.....	23	13.2.3.1. Reconditioning.....	52
		13.2.3.2. Measuring of Single Cell Voltages	53
		13.3. Useful tools.....	55

1 Using this manual

This operating and installation manual is intended to assist with the optimal operation of the HOPPECKE nickel-cadmium batteries used, as well as their installation and maintenance. This is the only way in which a maximum service life can be achieved.

Please contact your local authorised dealer:

- If you have any queries on this documentation.
- If there are local regulations or provisions that are not covered by this documentation or are contrary to its contents.

1.1 Target group of this document

All work on the battery system and the grid | power FNC®-cells must only be carried out by trained, fully qualified and authorised personnel:

- Personnel trained by HOPPECKE
- HOPPECKE experts

1.2 Means of Representation

The following icons and signal words are used in this operating and installation manual:



While working on batteries wear face protection (impact resistant visor according to EN 166 class F or similar), protective eye-glasses, protective gloves and clothing. Observe accident prevention regulations as well as EN 50110-1 and IEC 62485-2.



Danger!

Denotes an immediate hazard with a high level of risk that could lead to death or severe physical injury if it is not prevented.



Warning!

Denotes a potential hazard with a medium level of risk that could lead to death or severe physical injury if it is not prevented.



Caution!

Denotes a hazard with a low level of risk that could lead to minor or medium degree of physical injury if it is not prevented.



Attention!

Denotes a hazard in which the product, other objects or the environment may get damaged if it is not prevented.



Denotes first-aid measures.



Denotes important instructions to make best use of the product.

1.3 Notation of Nominal Data

Nominal battery data is used in accordance with the following notation in this operation and installation manual:

Notation	Meaning	Value
U_n	Nominal voltage	1.2 V multiplied by the number of cells connected in series
C_n	Nominal capacity	C_5 available capacity at discharge at I_5 (see nameplate) up to 1.0 V for each cell connected in series at nominal temperature
I_n	Nominal current	I_5 (see nameplate) = $C_n/5$ h
T_n	Nominal temperature	20 °C

1.4 Abbreviations and Definitions

The following table explains abbreviations and terms used in these installation, commissioning and operating instruction:

Abbreviation/Definition	Explanation
Reconditioning	Describes the defined discharge and subsequent charging of the battery with constant current. This allows the capacity losses of the battery system to be eliminated or reduced.
Float Charging	The charge of an accumulator to compensate for its self-discharge with the aim of keeping the accumulator fully charged.
Boost Charging	Indicates the charging of an accumulator with increased voltage and a defined current in order to fully charge the accumulator as quickly as possible.
Electrolyte	grid power FNC®-batteries are NiCd batteries and contain potassium hydroxide (KOH) as electrolyte with an addition of lithium hydroxide (LiOH). When handled properly, grid power FNC®-batteries are safe. Contact with the electrolyte is excluded.

2 Safety

Observe the safety instructions while handling the battery system and its components.

2.1 General Safety Instructions



Danger!

Caused by:

- Explosions
- Pressure waves
- Flying hot or molten substances

Avoid:

- Short-circuits
- Electrostatic charges and discharges
- Sparking or arcs



Danger!

Caused by:

- Voltages
- Electric shocks

Metallic parts of the batteries are always live. High current flow occurs if there is a short-circuit.

- Please be very careful when doing any work on the batteries in order to prevent severe injuries caused by electrical shocks or burns.
- Never place tools or other metallic objects on a battery.
- Remove watches and jewellery before doing any work on the batteries.
- Do not touch any exposed battery parts, connectors, terminals or poles.



Danger!

Reverse polarity of batteries or cells can cause overheating and thereby result in the electrolyte being ejected from the cell vents. Check for correct polarity before making connections.



Attention!

The cells of the batteries contain more than 0.1 % cadmium by weight:

- Symbol: Cd
- CAS number: 7440-43-9

2.2 Personal Protective Equipment



While working on batteries wear face protection (impact-resistant visor according to EN 166 class F or similar), protective eye-glasses, protective gloves and clothing!

Observe accident prevention regulations as well as EN 50110-1 and IEC 62485-2.

If working with lead-acid batteries, the following equipment must be provided at the very least:

- Insulated tools
- Rubber gloves
- Protective shoes
- Fire extinguisher
- Rubber apron
- Protective goggles
- Face protection (impact-resistant visor according to EN 166 class F or similar)
- Emergency eye wash

2.3 Specific Safety Instructions for grid | power FNC®-Battery Systems

2.3.1 Safety Instructions on Handling with Electrolyte

grid | power FNC®-cells are NiCd batteries and contain caustic potassium hydroxide solution as electrolyte.



Warning!

Contact with the electrolyte can occur if you work on open cells. Electrolyte can be discharged if the housing of an grid | power FNC®-cell is damaged. It can cause severe burn injuries on the skin and to the eyes.



While working on batteries wear face protection (impact resistant visor according to EN 166 class F or similar), protective eye-glasses, protective gloves and clothing.

Observe accident prevention regulations as well as EN 50110-1 and IEC 62485-2.



First-aid measures

Take the following actions if you have come into contact with the electrolyte:

Electrolyte solution on the skin or in the hair

- Dab it with a cotton or paper-based cloth, but do not wipe it off.
- Remove pieces of clothing that have been contaminated, and while doing so, avoid contact with the affected parts of the body as far as possible.
- Rinse off the affected parts for a longer period of time under flowing water.

Electrolyte in the eyes

- Gently rinse off the eye for up to 15 minutes with an eyewash or wash the eye in flowing water. Avoid excessive water pressure when doing so. Remove any contact lens as far as possible and continue to rinse off the eye.
- Consult an eye specialist or physician immediately.

Electrolyte in the mouth

- Rinse the mouth with water. DO NOT induce vomiting.
- Contact a doctor immediately or look for a hospital.



Use water to wash off clothes contaminated with electrolyte.

2.3.2 Safety Instructions on Charging the Battery System



Danger!

Danger of explosion due to formation of oxyhydrogen gas!

When the cells are charged, water is decomposed and a hydrogen-oxygen-gas mixture (oxyhydrogen gas) is formed, which already explodes with low energy input.

Keep any source ignition away from the battery system:

- Open flames or fire
- Smoking
- Glowing embers
- Flying sparks during grinding work
- Electrical sparks caused by switches or fuses
- Hot surfaces with temperature above 300 °C
- Electrostatic discharges

Work with electrically insulated tools that do not strike sparks. Ground yourself when working directly on the battery system.

Make sure that there is adequate ventilation in the container room in accordance with IEC 62485-2, so that the potential explosive gas mixture is discharged.



The following instructions are meant to prevent explosions caused by electrostatic discharges (Source: ZVEI – German Electrical and Electronic Manufacturers' Association – Professional Association for Batteries):

- Do not rub batteries with a plastic housing with a dry cloth or one made of synthetic material! Rubbing plastic surfaces generates electrostatic charge. Clean the batteries only with a cotton cloth moistened in water. Wiping with a cotton cloth moistened in water does not generate electrostatic charge.
- Do not rub batteries with clothing e. g. made of cotton! This can generate electrostatic charge.
- Wear shoes and clothes that prevent the formation of electrostatic charge on account of their special surface resistance (see chapter 2.2 Personal Protective Equipment on page 9).
- Use hand-held lamps with a mains cable without a switch (Protection class II) or hand-held lamps with a battery (Protection class IP54).
- Moisten a label of a battery (with water) before you pull off a label. Pulling off plastic labels can develop electrostatic charge.

2.3.3 Protection against dangerous body contact currents

In stationary battery installations, measures must be taken to guard against direct and indirect contact. For battery installations this protection can take the form of obstacles or distance.

According to IEC 62485-2:

- Battery installations with a rated voltage of 60 V ... 120 V must be accommodated in electrical operation areas.
- Battery installations with a rated voltage of more than 120 V must be accommodated in enclosed, electrical operating areas.

Doors of battery rooms and cubicles count as obstacles when they are identified by the following warning plates (fitted externally):

- Warning plate "Dangerous Voltage", if the battery voltage exceeds 60 V (see ISO 3864).
- Prohibition sign: "No fire, naked flame or smoking".
- Warning plate "Battery Room" to indicate electrolyte, explosive gases, dangerous voltages and currents.

2.3.4 Special hazards in the event of fire



Danger!

- Wear personal protective equipment against alkaline solutions (2.2 Personal Protective Equipment on page 9), for large battery systems also use breathing protection with self-sufficient breathing air supply.
 - Disconnect battery electrically.
 - Extinguish incipient fires with CO₂.
 - When extinguishing electric fires with water in low-voltage systems (up to 1 kV), maintain a spray distance of 1 m and a full spray distance of 5 m.
 - Wear alkali-resistant protective clothing! In case of contact with water, there is a risk of reactions with the electrolyte (caustic solution) and consequently of violent spraying.
 - Extinguish in short intervals. Otherwise, there is danger of explosion due to possible static charging on the battery housing.
- Failure to do so may result in death or serious injury.

3 Intended/Unintended Use

3.1 Intended Use

The grid | power FNC®-cells of the battery system are used to store and release electrical energy in standby applications, for example, uninterruptible power supply.

Intended use includes the following requirements:

- Operating the battery system only if it is in proper condition
- No deactivation or disassembly of safety devices
- Compliance with all instructions given in this operating and installation manual

3.2 Unintended Use



Danger!

Unintended use of the batteries can lead to personal injuries or damage to property. In case of unintended use, HOPPECKE Batterie Systeme GmbH shall not assume any liability for personal injuries or damage to property that result directly or indirectly from handling the batteries. The operator shall be solely responsible for the risks arising from unintended use.

Any other use than described under "Intended use" is not intended and therefore not permitted.

The unintended use of the product includes in particular:

- Operation in explosion-endangered areas
- Operation in safety-relevant applications, unless these applications are expressly specified or permitted in the product documentation
- Operation without permanent/insufficient fastening
- Operation outside the technical data
- Operation or storage outside the specified environmental conditions
- The electrical connection does not correspond to the documentation supplied with the battery

4 Directives, Legislation and Standards

Please observe the latest edition of the following rules and regulations:

- Accident prevention regulations, especially DGUV Regulation 1: Accident prevention regulation; Principles of prevention
- DIN EN ISO 20345 ("Personal safety gear – Safety boots")
- DIN VDE 0105 ("Operation of electrical equipment"), in particular, governs the requirements for quality and qualification for working on electrical equipment (DIN VDE 0105-100)
- DIN VDE 100/IEC 60364 ("Erection of low-voltage installations")
- DIN EN 50110/VDE 0105 ("Operation of electrical installations")
- IEC 62485/VDE 0510 ("Safety requirements for secondary batteries and battery installations"), particularly applicable for calculating the air ventilation required in battery rooms (in IEC 62485-2)
- DIN EN 60623/IEC 60623 ("Secondary cells and batteries containing alkaline or other non-acid electrolytes. Vented nickel-cadmium prismatic rechargeable single cells"), applicable primarily to the testing of cells (type test, series production test and field test)
- DIN EN 60993/IEC 60993 ("Electrolyte for vented nickel-cadmium cells")
- DIN VDE 0100-600 Low-voltage electrical installations – Part 6: Verification (IEC 60364-6:2006, modified); German implementation HD 60364-6:2007
- ADR/RID: European Treaty on the international transport of hazardous goods by road/Ordinance on the international transport of hazardous goods by rail
- IATA-DGR: Dangerous goods regulations – international air transport association. German: Gefahrgut-Bestimmungen – Internationale Flug-Transport-Vereinigung
- IMDG Code: International Maritime Code for Dangerous Goods, German: Gefahrgutkennzeichnung für gefährliche Güter im Seeschiffsverkehr
- Ordinance on the supervision of waste and residual materials (German Federal Law Gazette, 1996)

In addition, observe and follow all applicable territorial and national, corporate and project-specific regulations and accident prevention regulations.

5 Product description

grid | power FNC®-cells are connected to form battery systems and are deployed in standby applications.

Here, they fulfil one or more of the following functions:

- Buffering and supply of the low-voltage networks
- Providing power in case of an emergency
- To start a standby gen set/engine

5.1 grid | power FNC®-cell

grid | power FNC®-cell are nickel-cadmium cells, which are produced with fiber structure technology. It uses an extremely porous, three-dimensional synthetic fleece, metallized with nickel.

The particular characteristics are:

- The best volume/weight ratio by 90 % volume filling of the fiber electrodes with active material.
- High to very high values of current can flow during charging and discharging.
- No carbonates are formed in the electrolyte.
- The batteries have long service life and several charging cycles even under extreme temperature conditions.
- It withstands the most extreme of stress caused by shocks and vibrations.
- Cell housings made optionally either of polyether sulphone, polyamide or polypropylene.
- A large variety of constructions ranging from high and extremely flat to low with a large surface area.

The following drawing shows the internal structure of a grid | power FNC®-cell:

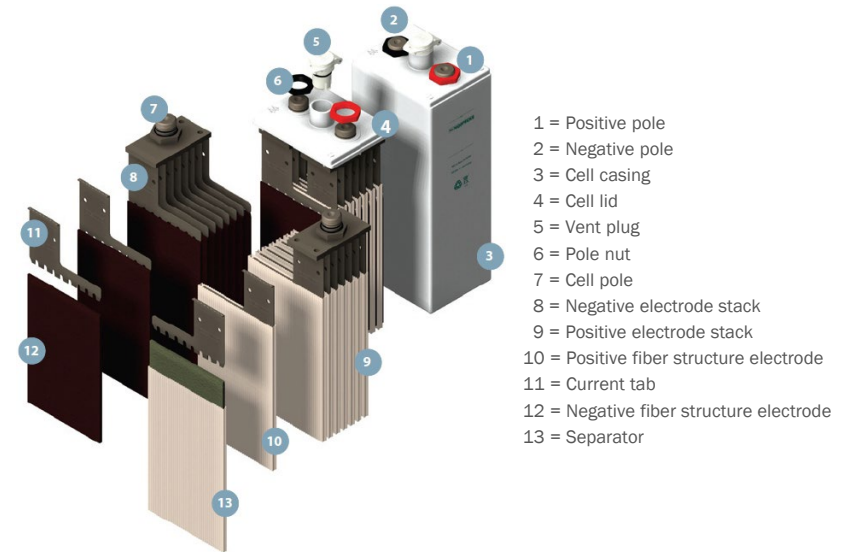

The electrolyte is a solution of potassium hydroxide (KOH) in distilled water with an addition of lithium hydroxide (LiOH). The standard electrolyte is designed for use in temperatures of between -25 °C and +45 °C. The lithium hydroxide in the electrolyte varies between the different cell types (X, H, M, L). DIN IEC 993 is valid for the production of the electrolyte.



When the cells are in operation, the density of the standard electrolyte is 1.19 kg/l ± 0.01 kg/l at the reference temperature of 20 °C (electrolyte density can be higher on delivery).



The electrolyte density is no indicator for the state of charge of nickel cadmium batteries.

For most FNC®-products, HOPPECKE supplies on request a special electrolyte that allows operation in low temperatures down to -45 °C.

5.2 Cell Plugs for Different Use Cases

Cell Plug	Description
	Yellow transport plug: grid power FNC®-cells are sealed with yellow transport plugs at delivery.
	Vent plug: The vent plug is the standard plug for FNC®-standby applications. It provides easy access to control and refill the electrolyte level. The lid contains a filter that works as backfire protection.
	Valve regulated plug (VR): A low-pressure valve recombines oxygen and hydrogen gasses inside the cell with up to 90 % efficiency. No water addition or filling is required over a 20 year service life when operated on float charge at 20 °C. Furthermore, the VR plug provides a backfire protection.

Furthermore, HOPPECKE provides grid | aquagen pro vent plugs that are described in a separate documentation. Contact HOPPECKE for further information.

5.3 Operation Modes (see also IEC 62485-2)

5.3.1 Standby parallel operation

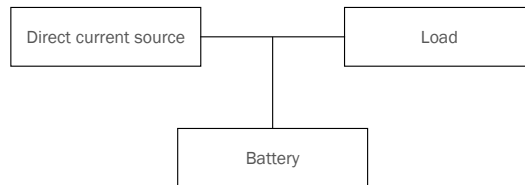

Characteristics of this operating mode are:

- Load, direct current source and battery are permanently connected in parallel.
- The charging voltage is the operating voltage of the battery and at the same time the system voltage.
- The direct current source (charging rectifier) is always able to supply the maximum load current and the battery charging current.
- The battery only supplies power when the direct current source fails.
- The charging voltage to be set is 1.40 ... 1.45 V per cell x number of cells connected in series (measured at the end poles of the battery). This is called float charging. The battery is permanently in the state of charging with float charge voltage.
- To shorten the recharge time, a charging stage can be used where the charging voltage is set to 1.50 ... 1.60 V per cell x number of cells connected in series. This is referred to as boost charging.
- After charging in boost charge, an automatic switchover to float charge takes place.

5.3.2 Buffer operation

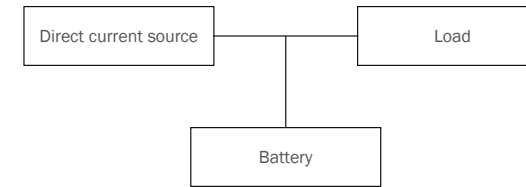

Characteristics of this operating mode are:

- Load, direct current source and battery are permanently connected in parallel.
- The charging voltage is the operating voltage of the battery and at the same time the system voltage.
- The direct current source (charging rectifier) is not able to supply the maximum load current at all times. The load current temporarily exceeds the rated current of the DC source. During this time, the battery supplies current.
- The battery is therefore not fully charged at all times.
- The charging voltage to be set is 1.45 ... 1.55 V per cell x number of cells connected in series (measured at the end poles of the battery).

5.3.3 Switching mode (charge/discharge mode)

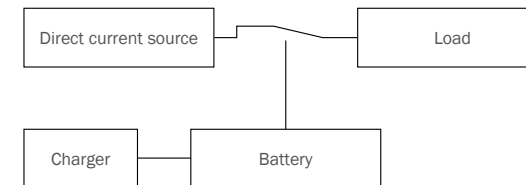

Characteristics of this operating mode are:

- When charging, the battery is disconnected from the consumer.
- The battery can be switched to the consumer as required.
- The charging voltage of the battery is max. 1.50 ... 1.60 V/cell (boost charge) or 1.40...1.45 V/cell (float charge), see also Section 5.3.1.
- The battery also can be charged with constant current I_5 . A secure shutdown criterion is required for this. Voltages up to 1.9 V/cell can occur.
- The charging process must be monitored.
- Secured shutdown criterion required (up to 1.9 V/cell).

5.4 Battery Charging Characteristic

In the temperature range from 10 °C up to 30 °C the battery system can be operated with the charging voltages as given in the table below:

Charging voltage at 20 °C in V per cell connected in series:				
Cell performance class according to EN 60623	Single-stage charging (IU)	2-stage charging (IUOU), float charging	2-stage charging (IUOU), Boost charge	Temperature compensation in V/degrees/cell; starting from 20 °C
L	1.55	1.45	1.55 ... 1.60	-0.003
M	1.52			
H	1.48			
X	1.45			
VR L	- ¹⁾	1.42	1.57	
VR M		1.40	1.55	

¹⁾ It is not recommended to use the single stage charging as charging characteristic for grid | power FNC® VR-cells, because you cannot achieve the advantages of the VR technology (no water addition or filling is required over the service life).

If the operating temperature differ from the range mentioned above, it is recommended to use a temperature compensated charging method.

The following diagram illustrates the charging voltage of each cell connected in series depending on the temperature of the electrolyte monitored by the charger (constant voltage, constant current characteristic, with current limitation).

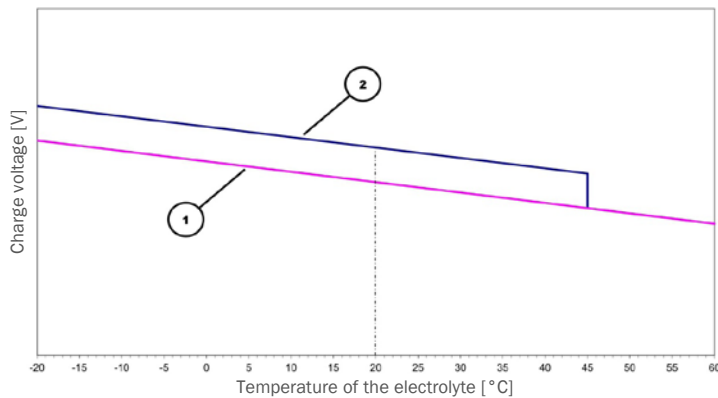

1 = Float charge
2 = Boost charge

The following conditions are applicable to the characteristic shown:

- Switch from float charge to boost charge:
The current permanently overshoots a value of $I_{20} = C_{tr}/20$ h.
- Switch from boost charge to float charge:
The current permanently undershoots a value of $I_{20} = C_{tr}/20$ h.
- Current limit $I_3 = C_{tr}/5$ h (recommended value, there may be deviations to higher or lower values of current)
- It is necessary to switch from boost charge to float charge when battery temperature is $\geq +45$ °C, to avoid damage to the battery. The hysteresis must be selected so that the switch to boost charge is only possible when the temperature is $\leq +40$ °C.
- If the battery temperature is ≥ 60 °C, the charging process must be switched off to prevent damage from cells. The hysteresis must be chosen in a way that charging is only switched on again when the temperature ≤ 55 °C.

5.5 Battery Capacity

A battery's capacity is the amount of electric charge it can deliver at the rated voltage.

The capacity, that can be charged to and can be taken from a battery, depends on the electrolyte temperature. This relationship is shown in the following illustration. It shows the charge acceptance of FNC®-cells (1: H type; 2: M and L types) charged with I_3 as a function of the electrolyte temperature:

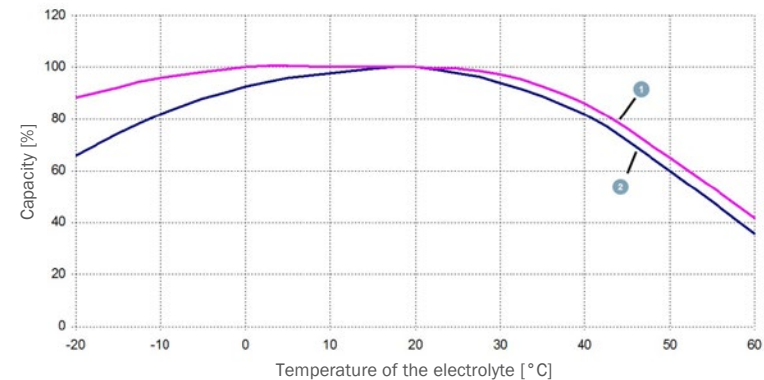

A test of the battery's capacity is part of the reconditioning, refer to 10.7 Reconditioning on page 39.

6 Transport

Batteries must be packed, marked and conveyed in accordance with the applicable transport regulations (ADR, IMDG Code, IATA). The cells of the battery should be protected against short-circuiting, sliding, falling over or damage and are to be secured to pallets by suitable means. There should be no dangerous traces of lye on the outside of the packages. Any special national regulations are to be observed.

Following receipt and inspection of batteries, the battery cells should be replaced in their original packing. This provides the battery with good protection against damage while it is in storage prior to installation.



Danger!

Damage to the battery housing can lead to spilling of electrolyte, resulting in chemical burns. Secure the load carefully during transport to prevent the battery housing from becoming damaged.



Caution!

The batteries are very heavy and can cause injuries and be damaged if they fall. Use safety boots. Use suitable equipment for transport.

Observe and follow the regulations for the transport of batteries, which are provided in the following sections.

6.1 Surface Transport (Road/Rail) according to ADR/RID

Filled batteries having the UN numbers 2795 (batteries/rechargeable batteries, wet, filled with alkalis) are not classified as hazardous goods requiring declaration during transport, if the following requirements are met (according to the ADR special regulation 598, section 3.3):

New batteries, if:	they are secured against sliding, turning over or damage.
	they are provided with carrying facilities, unless, for example, they are stacked on pallets.
	they do not have hazardous traces of caustic solutions or acids on the outside; they are protected against short-circuit.
Used batteries, if:	their housing is not damaged.
	they are protected against leakage, sliding, turning over or damage, for example, stacked on pallets.
	they do not have hazardous traces of caustic solutions or acids on the outside.
	they are protected against short-circuit.

“Used batteries” are those that are transported for the purpose of recycling after normal use.

If the conditions of special regulation 598 are not complied with, declare and transport new and used batteries as hazardous goods as follows:

UN hazardous goods class	8
UN no. (material number)	2795
Designation and description	BATTERIES, WET, FILLED WITH CAUSTIC SOLUTION
Packaging group	Not assigned to any packaging group
Hazard label	8
ADR tunnel restriction code	E

6.2 Transport by sea according to the IMDG Code

Declare grid | power FNC®-battery systems for sea freight as follows:

UN hazardous goods class	8
UN no. (material number)	2795
Proper shipping name	BATTERIES, WET, FILLED WITH CAUSTIC SOLUTION
Packaging group	Not assigned to any packaging group
Hazard label	8
EmS	F-A, S-B
Packing instructions	P801

6.3 Air Freight

Declare grid | power FNC®-battery systems for air freight as follows:

UN hazardous goods class	8
UN no. (material number)	2795
Proper shipping name	BATTERIES, WET, FILLED WITH CAUSTIC SOLUTION
Packaging group	Not assigned to any packaging group
Hazard label	8
Packing instruction	870

6.4 Checking the delivery

HOPPECKE Batterie Systeme GmbH packages your delivery with the greatest possible care so that it arrives undamaged.

- Check the delivery immediately for completeness (comparison with the delivery note).
- Check the goods for transport damage.
- Make a note:
 - Damage to the outer packaging
 - Visible stains or moisture that would indicate leaking electrolyte

If the delivery is incomplete or there is damage in transit:

- Write a short defect report on the delivery note before you sign it.
- Ask the carrier for an inspection and make a note of the name of the inspector.
- Write a defect report and send it within 14 days to HOPPECKE Batterie Systeme GmbH and the forwarding agent.

Inspect goods for defects:

- Follow the instructions in chapter 2 Safety on page 8.
- After delivery, unpack the batteries as soon as possible and check them for defects by visually inspecting them, see 10.1 Checking for Cleanliness and Condition of the Battery System on page 33.



If you notify the freight forwarder too late of defects or incompleteness, this may result in the loss of your claims.

7 Storage

The service life of the battery system begins with the delivery ex works from HOPPECKE. Storage periods must be taken into consideration in their entirety for the service life duration.

Unpack the battery system as soon as possible after delivery, install it and put it into operation, see 8 Installation on page 22.

In case this is not possible:

- Store the batteries in a clean, dry and frost-free room.
- Protect the batteries against mechanical damage and contamination.
- Do not expose the batteries to direct sunlight.
- Do not stack the batteries on one another. Please observe and follow project-specific regulations applicable, if any.



The ideal storage temperature is +20 °C.
The maximum storage temperature is +60 °C.
A too high storage temperature leads to faster self-discharge and premature ageing of the battery system.

7.1 Storage of Filled and Charged (FC) Cells



The storage period of the batteries should not exceed three months after manufacturing and delivery from the factory.

If the foreseeable storage period exceeds three months, discharge the batteries as described below. The battery system prepared in this way can be stored for three years.

The manufacturing date of the grid | power FNC®-cells is stamped on the top of each battery cell. Each cell has a 9-digit cell code on top of the cell lid. The last four digits indicate the week and year of production.

Example:

xxxx2610 → Production week 26; Production year 2010

Steps to prepare the battery system for storage:

1. Remove the plug of each grid | power FNC®-cell.



Valid for grid | power FNC® VR-cells:

Remove a VR plug carefully. It is recommended to use the HOPPECKE plug opener (Mat. No. 4142500125).

Alternatively use a small, slot screwdriver. Grab the plug with your hand and slowly twist and vertically pull out the plug from the cell opening.

Wear personal protective equipment because grid | power FNC® VR-cells operate under pressure. Removing a VR plug can release electrolyte spray.

2. Discharge the batteries by using a charging/discharging device with nominal current I_5 (nominal capacity $C_5/5$ h) until the battery voltage has dropped to 1.0 V per cell.

3. Seal each grid | power FNC®-cell with a yellow transport plug.



Filled and charged (FC) grid | power FNC®-cells prepared in this manner can be stored up to three years.

After three years, a recondition charge is necessary, see 10.7 Reconditioning on page 39.



If you want to put the stored grid | power FNC®-cells into operation, you have to charge the cells for recommissioning. For information, refer to 9.2 Commissioning of Unfilled and Uncharged (UU) and Filled and uncharged (FU) grid | power FNC®-cells on page 30.

7.2 Storage of Unfilled and Uncharged (UU) and Filled and Uncharged (FU) grid | power FNC®-cells



Ensure that the grid | power FNC®-cells are sealed with yellow transport plugs.

grid | power FNC®-cells (UU and FU) can be stored up to three years.

After three years the UU cells must be filled and a recondition charge is necessary, see 10.7 Reconditioning on page 39. If you store the grid | power FNC®-cells longer than three years, contact HOPPECKE before you put the cells into operation.



If you want to put the stored grid | power FNC®-cells into operation, you have to charge the cells for recommissioning. For information, refer to 9.2 Commissioning of Unfilled and Uncharged (UU) and Filled and uncharged (FU) grid | power FNC®-cells on page 30.

8 Installation



Danger!

Risk of serious injury or death caused by:

- high voltages
- electric shocks

Metallic parts of the batteries are always live. High current flow occurs if there is a short-circuit.

- Be very careful when doing any work on the batteries in order to prevent severe injuries caused by electrical shocks or burns.
- Never place tools or other metallic objects on a battery.
- Remove watches and jewelry before doing any work on the batteries.
- Do not touch any exposed battery parts, connectors, terminals or poles.

Use insulated tools and wear personal protective equipment.

8.1 Mounting a Rack or Cabinet

8.1.1 Before Mounting a Rack or Cabinet

Before starting assembly it must be ensured that the battery room is clean and dry and has a door which can be closed. The battery room must be provided with warning signs conforming to IEC 62485-2 (see also 2.3.3 Protection against dangerous body contact currents on page 10).

Particular attention should also be paid to the following:

- Ensure correct floor loading and floor quality (access routes and battery room).
- Ensure that the mounting surface (floor of the battery room or electrolyte tray) is resistant to electrolyte.
- Protection against sources of ignition (naked flame, glowing matter, electrical switches) in the vicinity of the cell opening. Calculate "filament distance" as specified in IEC 62485-2 (Chapter 7.7).
- Ensure adequate ventilation according to IEC 62485-2.
- Agreement with other persons working in the same room (ensures trouble-free installation).
- Provide for leakage resistances of the floor according to IEC 62485-2.

HOPPECKE will be pleased to help you in procuring suitable racking.

8.1.2 Checking the Scope of Delivery

Check all goods delivered for completeness and for any signs of damage.

Clean all parts if necessary.

Note and follow the accompanying documentation. This documentation should comprise an assembly drawing for the rack or cubicle, together with battery connection instructions. If the documents required for correct assembly of the rack are missing, please follow the project documentation or ask for this before starting assembly.

Only undamaged cells may be used, since otherwise the whole battery may be adversely affected by escaping electrolyte.

8.1.3 Mounting a Rack

Assemble the rack according to the instructions delivered from the manufacturer.

Observe the minimum distances according to IEC 62485-2.



Danger!

Risk of serious injury or death caused by high voltages and electric shocks.

If component voltages in excess of 120 V are reached or if the rated voltage of the battery is above this value, then a minimum distance of 1.5 m is to be maintained between non-insulated connections or connectors and earthed parts (e. g. water pipes, heating) and between the end terminals of the battery.

8.1.4 Mounting a Cabinet

Assemble the cabinet according to its documentation, if it is supplied in separate parts.

Observe the minimum distances according to IEC 62485-2.

8.1.5 Ventilation Requirements

Ensure that the battery room or cabinet has an adequate ventilation. The ventilation has to keep the hydrogen concentration below the threshold of 4 % by volume during battery charging, in accordance with IEC 62485-2.

The volume of air which must be changed hourly may be calculated by the following formula:

$Q = 0.05 * n * I$	<p>Q = volume of air in m³ per hour</p> <p>n = number of FNC[®]-cells of the battery system</p> <p>I = charging current in ampere (A)</p>
--------------------	---

The battery room or cabinet can be natural or forced ventilated. If natural ventilation (airflow 0.1 m/s) is used the inlet and outlet openings must have a minimum cross-section, that is calculated as follows:

$A = 28 * Q$	<p>A = cross-section of vent in cm²</p> <p>Q = volume of air in m³ per hour</p>
--------------	---

Provide ventilation openings at suitable locations to obtain the most advantageous conditions for air exchange.

8.2 Installing the Battery System



Danger!

Risk of serious injury or death caused by:

- high voltages
- electric shocks

Metallic parts of the batteries are always live. High current flow occurs if there is a short-circuit.

- Be very careful when doing any work on the batteries in order to prevent severe injuries caused by electrical shocks or burns.
- Never place tools or other metallic objects on a battery.
- Remove watches and jewellery before doing any work on the batteries.
- Do not touch any exposed battery parts, connectors, terminals or poles.

The grid | power FNC®-cells are delivered according to your order:

- Filled and charged (FC)
- Unfilled and uncharged (UU)
- Filled and uncharged (FU)

The cells are supplied sealed with yellow transport plugs or the standard vent plugs are already mounted.

grid | power FNC® VR-cells are supplied sealed with yellow transport plugs. The VR plugs are separately enclosed in the delivery.



It is recommended to leave the yellow transport plugs on the cells until you have completed the connection and installation of the battery system.

8.2.1 Preliminary Work on Unfilled and Uncharged grid | power FNC®-cells



Attention!

The electrolyte is a solution of potassium hydroxide (KOH) in distilled water with an addition of lithium hydroxide (LiOH).

It is recommended to use electrolyte delivered by HOPPECKE.

If this is not possible for some reasons contact HOPPECKE for instructions on mixing.



Attention!

Fill immediately (within 1 hour) electrolyte to an unfilled and uncharged cell after you have removed the yellow transport plug. Prolonged contact of atmospheric oxygen to the electrodes can negatively influence the performance.

1. Remove the yellow transport plugs.

2. Fill electrolyte to the each grid | power FNC®-cell up to the minimum level +10 mm.



Topping-up with electrolyte to the maximum level takes place after the commissioning of the battery system, see 9 Commissioning on page 27.

3. Let the cells rest for 1 hour.

4. Insert the yellow transport plugs again.



Attention!

Wait at least 12 hours before you begin with the commissioning works, see 9 Commissioning on page 27.

8.2.2 Equipping the Rack or Cabinet

1. Check and clean each cell.

The contact surfaces of the terminals and the connectors must be in a clean and proper condition.

2. Place the individual cells:

- one after the other
- with correct polarity (for verification use a suitable measuring instrument)
- as shown on the connection drawing, and at right-angles to the horizontal support rails



You can place the individual cells without any clearance.

A distance of at least 5 mm between the cells is recommend in warmer environments (> 35 °C).

8.2.3 Connecting the Battery System

Connect the grid | power FNC®-cells electrically after you have placed them to a rack or cabinet. Use only original HOPPECKE accessories.

Several grid | power FNC®-cells can form a row. One or more rows form the battery system.

1. The contacts must be clean and free from any traces of corrosion.

2. Connect the grid | power FNC®-cells to each other to form a row.

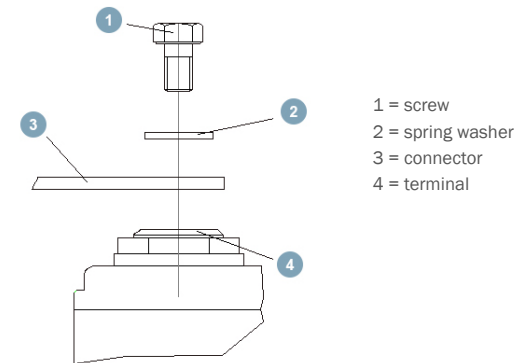

Use spring washers.

Spring washers ensure a permanent and secure fit of the connectors on the terminal posts.

Torque:

M8 = 20 Nm ± 1 Nm

M10 = 25 Nm ± 1 Nm

3. Install isolation rails to the connectors.

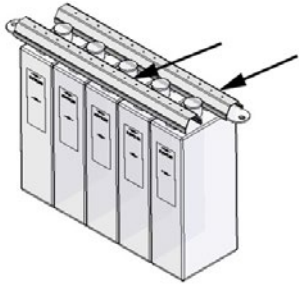

The isolation rails are available as a yard good, also in flame retardant material according to UL94-V0. They can be used for 3 mm and for 6 mm standard connectors.

4. Connect the rows to each other.



Attention!

Risk of damage to the battery system.
The cross section of the row connectors must match to the current strength.

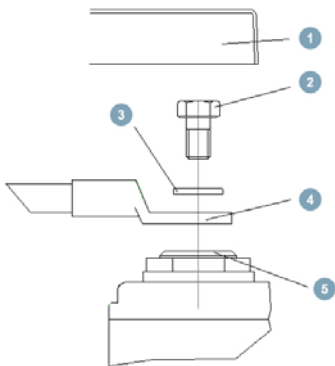

Row or end connector:

- 1 = cover cap
- 2 = screw
- 3 = spring washer
- 4 = cable with cable eye
- 5 = terminal

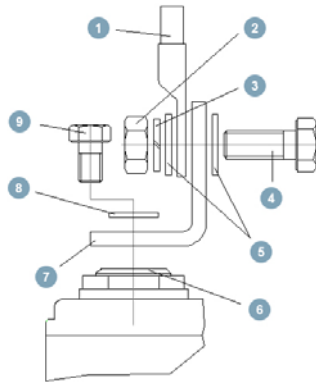

Row or end connector with connection bracket:

- 1 = cable with cable eye
- 2 = nut
- 3 = spring washer
- 4 = screw
- 5 = washer
- 6 = terminal
- 7 = connection bracket
- 8 = spring washer
- 9 = screw



Ensure that the wiring of the row and end connectors is proof against short-circuits: Use wiring material with at least 3 kV dielectric strength. Let a distance in air of at least 10 mm between the wiring and electrically conductive parts. Alternatively, additional insulation may be used. Any mechanical loading of the end terminals is to be avoided by the fixing of the row and end connectors. Avoid any mechanical load on the terminals with connecting the row and end connectors. Use only original HOPPECKE accessories.

8.2.4 Labelling the Battery System

You have to attach visible polarity labels to the end terminals of the battery. It is recommended to equip the FNC®-cells with consecutive numbers (from the positive to the negative terminal of the battery). Battery systems with a nominal voltage ≥ 75 V installed in the EU must carry a CE conformity marking. Contact HOPPECKE for further information.

9 Commissioning



Danger!

Danger of explosion due to formation of oxyhydrogen gas!

When the cells are charged, water is decomposed and a hydrogen-oxygen-gas mixture (oxyhydrogen gas) is formed, which already explodes with low energy input.

Keep any source ignition away from the battery system:

- Open flames or fire
- Smoking
- Glowing embers
- Flying sparks during grinding work
- Electrical sparks caused by switches or fuses
- Hot surfaces with temperature above 300 °C
- Electrostatic discharges

Work with electrically insulated tools that do not strike sparks.

Ground yourself when working directly on the battery system.

Make sure that there is adequate ventilation in the container room in accordance with IEC 62485-2, so that the potential explosive gas mixture is discharged.

9.1 Charging Procedures for the Initial Commissioning

9.1.1 Charging with Constant Current

It is highly recommended to charge the HOPPECKE grid | power FNC®-cells during initial commissioning with a constant current for a defined period of time.

The diagram below exemplarily shows the charge voltage of one cell depending on time during charge with constant current I_5 for 7.5 hours:

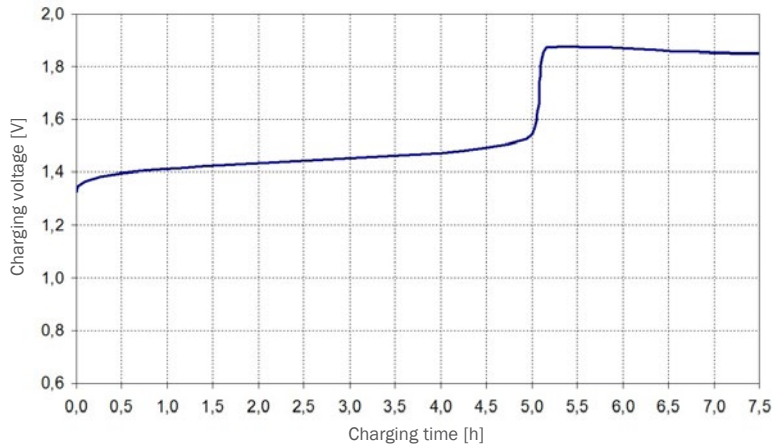

Voltages up to 1.9 V per cell can occur during the initial charging with constant current. If your battery charger cannot achieve this performance for the complete battery system, the system has to be split into two or more groups. Charge the groups separately.

If you decrease the constant current, the charging time is increased.
Example:

- I_5 = 7.5 hours
- I_{10} = 15 hours
- I_{20} = 30 hours

...



9.1.2 Charging with Constant Current and Constant Voltage (CCCV)



Attention!

The CCCV charging must not be used for unfilled and uncharged (UU) FNC®-cells.

As an option, you can use the constant current, constant voltage charging method for initial commissioning of the battery system. This method takes longer to charge the battery system to approximately 100 % than the constant current charging (see 9 Commissioning on page 27).

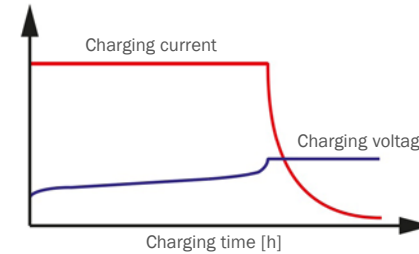

First, the grid | power FNC®-cells are charged with a constant charging current. The maximum current has to be limited to $\leq I_5$ (e. g. for a 100 Ah battery the current $I_5 = 20$ A).

As soon as the voltage limitation takes place, the charging current decreases automatically.

The following table shows the specified charging time for charging with limited charging voltage:

Voltage [V]	Time [h]	Current [A]	Capacity [Ah]	Description									
1.9 V/cell	7.5	I_5	$1.5 * C_n$	This is the recommended charging method, see 9.1.1 Charging with Constant Current on page 28.									
	15	I_{10}			-								
1.85 V/cell	10.5	I_5		$1.5 * C_n$	If you limit the charging voltage, the charging time must be extended. Every step of 0.05 V increases the charging time by 3 hours if the charging current is I_5 .								
	21	I_{10}											
1.8 V/cell	13.5	I_5				$1.5 * C_n$	Initial commissioning is only possible with charging voltages ≥ 1.65 V to get the capacity of the battery system to approximately 100 %.						
	27	I_{10}											
1.75 V/cell	16.5	I_5						$1.5 * C_n$	Initial commissioning is only possible with charging voltages ≥ 1.65 V to get the capacity of the battery system to approximately 100 %.				
	33	I_{10}											
1.7 V/cell	19.5	I_5								$1.5 * C_n$	Initial commissioning is only possible with charging voltages ≥ 1.65 V to get the capacity of the battery system to approximately 100 %.		
	39	I_{10}											
1.65 V/cell	22.5	I_5										$1.5 * C_n$	Initial commissioning is only possible with charging voltages ≥ 1.65 V to get the capacity of the battery system to approximately 100 %.
	45	I_{10}											

9.2 Commissioning of Unfilled and Uncharged (UU) and Filled and uncharged (FU) grid | power FNC®-cells



Danger!

Danger of explosion due to formation of oxyhydrogen gas!

When the cells are charged, water is decomposed and a hydrogen-oxygen-gas mixture (oxyhydrogen gas) is formed, which readily explodes with low energy input.

Keep any ignition source away from the battery system:

- Open flames or fire
- Smoking
- Glowing embers
- Flying sparks during grinding work
- Electrical sparks caused by switches or fuses
- Hot surfaces with temperature above 300 °C
- Electrostatic discharges

Work with electrically insulated tools that do not create sparks.

Ground yourself when working directly on the battery system.

Make sure that there is adequate ventilation in accordance with IEC 62485-2, so that the potential explosive gas mixture is discharged.



Danger!

Valid for unfilled and uncharged (UU) grid | power FNC®-cells

After filling the electrolyte, wait at least 12 hours before you begin with the commissioning works.

1. Remove the transport plug of each grid | power FNC®-cell.
2. Recommended: Insert a gas venting tube on each grid | power FNC®-cell, (HOPPECKE Mat. No.: 4143180100).
3. Measure the temperature of the battery system by inserting a suitable glass thermometer through the opening of a cell. The cell to be measured should be installed in the center of the system, in order to capture the warmest possible location of the system.
4. Charge the battery system using a constant current of I_g for 7.5 hours.



Attention!

The battery system must not exceed a temperature of 45 °C during charging.

Once a temperature of 45 °C is reached, stop the charging process.

Make a note of the remaining charging time.

Only continue charging when the cell temperature has dropped below 25 °C.

Complete the remaining charging time of the 7.5 hours after the battery system has cooled.

Should the battery again reach a temperature of 45 °C before the charging time of 7.5 hours is completed, interrupt the charging process again, and repeat as necessary.

5. Allow the battery system to rest for at least 4 hours.
6. Remove the gas venting tubes.
7. Thoroughly remove any contamination on the battery system with a soft, damp cloth with water.
8. Refill the electrolyte level of each grid | power FNC®-cell with electrolyte to maximum.
9. Place the (vent/VR) plug vertically and insert it carefully to each FNC®-cell.
10. Keep a log of your actions, see 13.1 Commissioning Record on page 44.

9.3 Commissioning Filled and Charged (FC) FNC®-cells



If the initial commissioning is within three months from the manufacturing date, the instructions in this chapter are not mandatory.

The manufacturing date of the grid | power FNC®-cells is stamped on the top of each battery cell. Each cell has a 9-digit cell code on top of the cell lid. The last four digits indicate the week and year of production.

Example:

xxxx2610 → Production week 26; Production year 2010



Danger!

Danger of explosion due to formation of oxyhydrogen gas!

When the cells are charged, water is decomposed and a hydrogen-oxygen-gas mixture (oxyhydrogen gas) is formed, which readily explodes with low energy input.

Keep any ignition source away from the battery system:

- Open flames or fire
- Smoking
- Glowing embers
- Flying sparks during grinding work
- Electrical sparks caused by switches or fuses
- Hot surfaces with temperature above 300 °C
- Electrostatic discharges

Work with electrically insulated tools that do not create sparks.

Ground yourself when working directly on the battery system.

Make sure that there is adequate ventilation in accordance with IEC 62485-2, so that the potential explosive gas mixture is discharged.

1. Measure the voltages of the individual cells using a digital multimeter and note the values in the commissioning report see 13.1 Commissioning Record on page 44.
The open circuit voltage of a fully charged, non-defective cell at 20 °C must be ≥ 1.3 V.



The individual cell voltages should not vary by more than ± 50 mV from the mean of all cell voltages. If the open circuit voltage of a cell is < 1.2 V, contact HOPPECKE service.

2. Remove the transport plug of each grid | power FNC®-cell.
3. Recommended: Insert a gas venting tube on each grid | power FNC®-cell, (HOPPECKE Mat. No.: 4143180100).
4. Discharge the battery system by using a charging/discharging device with nominal current I_g , until the voltage of the battery system has dropped to 1.0 V per cell.
5. Allow the battery system to rest with disconnect load for at least 8 hours, ideally overnight.
6. Measure the temperature of the battery system by inserting a suitable glass thermometer through the opening of a cell. The cell to be measured should be installed in the center of the system, in order to capture the warmest possible location of the system.
7. Charge the battery system using a constant current of I_g for 7.5 hours.



Attention!

The battery system must not exceed a temperature of 45 °C during charging. Once a temperature of 45 °C is reached, stop the charging process. Make a note of the remaining charging time. Only continue charging when the cell temperature has dropped below 25 °C. Complete the remaining charging time of the 7.5 hours after the battery system has cooled. Should the battery again reach a temperature of 45 °C before the charging time of 7.5 hours is completed, interrupt the charging process again, and repeat as necessary.

8. Allow the battery system to rest for at least 4 hours.
9. Remove the gas venting tubes.
10. Thoroughly remove any contamination on the battery system with a soft, damp cloth with water.
11. Refill the electrolyte level of each grid | power FNC®-cell with distilled water to maximum.
12. Place the (vent/VR) plug vertically and insert it carefully to each FNC®-cell.
13. Keep a log of your actions, see 13.1 Commissioning Record on page 44.

9.4 Capacity Testing of Batteries According to DIN IEC 60623

The capacity test is part of the recondition charge, see 10.7 Reconditioning on page 39.

10 Maintenance

- Have the batteries serviced regularly and properly by HOPPECKE qualified personnel or personnel authorised by HOPPECKE Batterie Systeme GmbH.
- Observe the notes in chapter 2 Safety on page 8.
- Correct maintenance of the battery system and its components is a basic requirement to ensure a satisfactory service life of the battery.
- To ensure that your battery remains in optimum condition, the following maintenance programme must be fulfilled.
- It is also mandatory to keep maintenance records, that include details of the temperature in the room in which the batteries are installed or stored.

The following table shows the measures for preventive maintenance:

Activity	Interval	Reference
Visual inspection of the battery system and the FNC®-cells	6 months	10.1 Checking for Cleanliness and Condition of the Battery System
Checking the electrolyte level		10.2 Checking the Electrolyte Levels on page 34
Measuring the charging voltage of the battery system		10.3 Measuring the Charging Voltage on page 36
Testing the isolation resistance of the battery system	12 months	10.4 Testing the Insulation Resistance on page 36
Cleaning the battery system and its parts		10.5 Cleaning on page 37
Filling up electrolyte level with distilled water		10.6 Fill up the Electrolyte Level with Distilled Water on page 37
Measuring the individual cell voltage of all FNC®-cells	5 years	Is part of the reconditioning.
Reconditioning		10.7 Reconditioning on page 39



Enter the activities and the measured values in a maintenance report as evidence in the event of a warranty claim.

10.1 Checking for Cleanliness and Condition of the Battery System

A clean battery is absolutely necessary, in order to avoid reduced service life and availability of the battery. Cleaning of cell carriers, trays, racks and insulators is necessary in order to maintain the required insulation of the cells from each other, from the earth, and from other extraneous conductive parts. In addition, damage caused by corrosion and leakage can be avoided. Cleaning of batteries is not only necessary to ensure high availability required, but is also an essential part of accident prevention regulations.

1. Keep the cells of the battery system clean and dry since dust and moisture can lead to leakage currents.
2. Keep screws, connectors and cable lugs clean.
3. Thoroughly remove any contamination using a clean, damp cloth.
4. Check the batteries according to the following criteria:
 - Contamination: Battery cells must be clean
 - Ventilation: Ventilation openings must be unobstructed
 - Cells, the racks or cabinets must be free from mechanical damage
 - Connectors, screws and cables must be tight
 - Plugs are mounted correctly (no electrolyte stains on the plugs or on the cells)
5. Keep a log of your maintenance activities, see 13.2 Maintenance Log on page 47.

10.2 Checking the Electrolyte Levels



Valid for grid | power FNC® VR-cells

No water addition or filling is required over the service life when operated on the recommended specific float charge voltage at 20 °C. However, it is recommended to inspect the electrolyte levels every six months visually.



Warning!

Contact with the electrolyte can happen when measuring the electrolyte level. It can cause severe chemical burns to the skin and severe damage to the eyes.



While working on batteries wear face protection (impact resistant visor according to EN 166 class F or similar), protective eye-glasses, protective gloves and clothing. Observe accident prevention regulations as well as EN 50110-1 and IEC 62485-2.

You can see the level of the electrolyte from the outside, if the housing of the FNC®-cells are made of polypropylene (PP).



If the following conditions are true, no further action is necessary:

- The electrolyte levels of all FNC®-cells are higher than the middle between minimum and maximum. Otherwise, you have to refill the electrolyte levels with distilled water to the maximum level, refer to 10.6 Fill up the Electrolyte Level with Distilled Water on page 37.
- The difference between the FNC®-cells must be not greater than 5 mm.

If the level of the electrolyte is not visible, use the glass tube for measuring (HOPPECKE Mat. No.: 4144140010) as described below.

1. Open or remove the plug of each grid | power FNC®-cell.



Valid for grid | power FNC® VR-cells:

If you want to check the electrolyte level with the glass tube for measuring, remove the VR plug carefully. It is recommended to use the HOPPECKE plug opener (Mat. No. 4142500125). Alternatively use a small, slot screwdriver. Grab the plug with your hand and slowly twist and vertically pull out the plug from the cell opening. Wear personal protective equipment because grid | power FNC® VR-cells operate under pressure. Removing a VR plug can release electrolyte spray.



It is recommended to use the glass tube for measuring (HOPPECKE Mat. No.: 4144140010) to check the electrolyte.

2. Check the electrolyte level in each cell with the glass tube for measuring (HOPPECKE Mat. No.: 4144140010).
3. Keep the top opening of the glass tube free and guide it into the cell until it meets some resistance.
4. Close the top opening of the glass tube with the index finger and remove it from the cell.

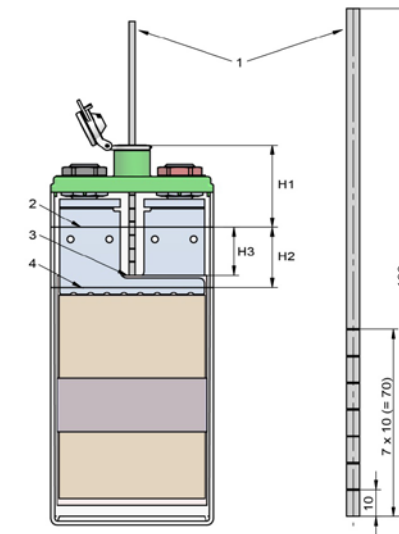

1 = Glass tube for measuring

2 = MAX electrolyte level

3 = Top of separator

4 = MIN electrolyte level

H1 = Height from open cell plug to MAX electrolyte level

H2 = Reserve of electrolyte between MIN and MAX label

H3 = Measurable electrolyte height range

The following table shows the measured electrolyte level according to the cell type (distinguished by the enclosure height):

	Enclosure height [mm]	Level measured with the glass tube [mm]	Description
	217	5	Middle between Minimum and Maximum
		19	Maximum level
	276	15	Middle between Minimum and Maximum
		36	Maximum level
	373	22.5	Middle between Minimum and Maximum
		55	Maximum level

5. If the level is higher than the middle between minimum and maximum level no further action is necessary. Otherwise, you have to refill the electrolyte levels with distilled water to the maximum level, refer to 10.6 Fill up the Electrolyte Level with Distilled Water on page 37.



Warning!

Use only distilled water in accordance with EN 60993 for topping up the battery cells. Filling the cells with acid or acidic water destroys the cells of the grid | power FNC®-batteries. Tap water impairs the battery performance.

6. Close or remount the plugs.
7. Clean the battery system if necessary, see 10.5 Cleaning on page 37.
8. Keep a log of your maintenance activities, see 13.2 Maintenance Log on page 47.

10.3 Measuring the Charging Voltage

The measurement of the voltage values is used to detect and identify faults. Recording the voltage values measured helps in doing so.



Precondition

The battery system is connected to a charging device and is being charged.



Danger!

Depending on installation conditions, there can be a risk of death or severe injuries when establishing access to or accessing the battery system. Carry out the prescribed safety measures that apply to the required maintenance works.

1. Measure the charging voltage of the battery system.
2. Measure the temperature of the battery system.
3. Control the measured charging voltage with the charging characteristic, refer to 5.4 Battery Charging Characteristic on page 16.
4. Note the measured values, see 13.2 Maintenance Log on page 47.

10.4 Testing the Insulation Resistance

The insulation resistance of a battery is a measure of the conductivity. It results of moisture and contamination of the battery between the battery poles and the chassis (rack/cabinet). Ideally, no conduction should take place here if the insulation resistance of the battery is infinitely large.

When commissioning a new battery, the insulation resistance must be $> 1 \text{ M}\Omega$. This value falls with the operating time (caused by aerosols from the batteries, condensation and dust) and, in accordance with IEC 62485-2, it should not fall below the value of 100Ω per volt of nominal voltage.



Minimum value for the battery system:

$100 \Omega \times 1.2 \text{ V} \times \text{number of cells of the battery connected in series.}$

For grid | power FNC®-batteries, an insulation resistance measuring instrument with a test voltage of 500 V/1000 V must be used (according to DIN VDE 0100-600).

Use a suitable measuring device, e. g., GOSSEN METRAWATT METRISO 5000 D-PI.

Nominal battery voltage $\leq 500 \text{ V}$ = set the measuring device to 500 V/DC, 1 minute

Nominal battery voltage $> 500 \text{ V}$ = set the measuring device to 1000 V/DC, 1 minute



Attention!

An insulation test voltage of 500 V/1000 V may damage other components connected to the battery. Disconnect the battery from the load if you measure the insulation resistance.



Caution!

While carrying out measurements with an insulation resistance measuring instrument there is the risk of getting an electric shock. Observe and follow the safety precautions described in the documentation of the insulation resistance measuring instrument.

1. Measure the insulation resistance between plus pole of the battery and one metallic part of the battery rack/cabinet or central earthing point.
2. Measure the insulation resistance between the minus pole and a metallic part of the battery rack/cabinet or central earthing point.
3. Clean the battery system, if the measured values are lower than the minimum value (see 10.5 Cleaning).
4. Measure the insulation resistance again according to step 1 and 2.
5. Keep a log of your maintenance activities, see 13.2 Maintenance Log on page 47.

10.5 Cleaning

A clean battery is absolutely necessary, in order to avoid reduced service life and availability of the battery.



Attention!

Solvent and wire brushes can attack the walls of the battery cells. Do not use solvents or wire brushes to clean the batteries.



Attention!

Cleaning water that penetrates into the battery or dirt particles can damage it. While cleaning the battery, the battery cells must be sealed with the cell plugs or transport plugs.

1. Clean the battery with a clean, damp cloth and with water without adding any detergents or cleaning agents.
2. Rinse off the cell plugs with water if this is necessary.
3. Dry the surfaces of the battery after cleaning them using a clean, damp cloth or with the help of compressed air.
4. Any liquids which entered the battery rack or cabinet must be extracted and disposed of in accordance with waste monitoring guidelines.
5. To protect bare connectors and terminals against corrosion, a thin layer of neutral Vaseline or anti-corrosion lubricant can be used.
6. Keep a log of your maintenance activities, see 13.2 Maintenance Log on page 47.

10.6 Fill up the Electrolyte Level with Distilled Water



Valid for grid | power FNC® VR-cells

No water addition or filling is required over the service life if the battery system operates on float charge at $20 \text{ }^\circ\text{C}$.

If, however, you have to fill up the electrolyte level with distilled water, remove the VR plug carefully. It is recommended to use the HOPPECKE plug opener (Mat. No. 4142500125)

Alternatively use a small, slot screwdriver. Grab the plug with your hand and slowly twist and vertically pull out the plug from the cell opening.

Wear personal protective equipment because grid | power FNC® VR-cells operate under pressure. Removing a VR plug can release electrolyte spray.



Contact with the electrolyte can happen when measuring the electrolyte level. It can cause severe chemical burns to the skin and severe damage to the eyes.

Warning!



While working on batteries wear face protection (impact resistant visor according to EN 166 class F or similar), protective eye-glasses, protective gloves and clothing.

Observe accident prevention regulations as well as EN 50110-1 and IEC 62485-2.



Precondition

You have checked the electrolyte level as described in 10.2 Checking the Electrolyte Levels on page 34.

1. Refill the electrolyte levels with distilled water to the maximum level.

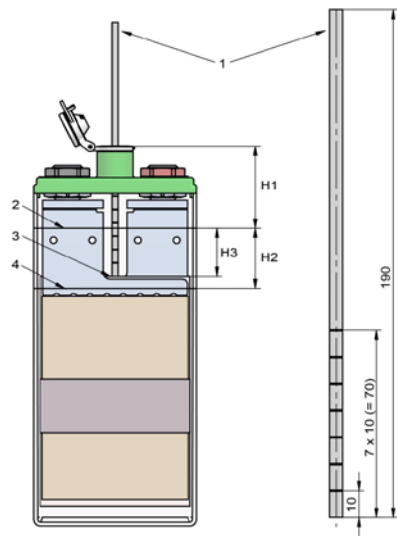

- 1 = Glass tube for measuring
- 2 = MAX electrolyte level
- 3 = Top of separator
- 4 = MIN electrolyte level
- H1 = Height from open cell plug to MAX electrolyte level
- H2 = Reserve of electrolyte between MIN and MAX label
- H3 = Measurable electrolyte height range

Maximum electrolyte levels according to the cell type (to distinguish by the enclosure height):

	Enclosure height [mm]	Level measured with the glass tube [mm]	Description
	217	5	Middle between Minimum and Maximum
		19	Maximum level
	276	15	Middle between Minimum and Maximum
		36	Maximum level
	373	22.5	Middle between Minimum and Maximum
		55	Maximum level



Attention!

Use only distilled water in accordance with EN 60993 for topping up the battery cells. Filling the cells with acid or acidic water destroys the cells of the FNC®-batteries. Tap water impairs the battery performance.

2. Clean the battery system if necessary, see 10.5 Cleaning on page 37.

3. Keep a log of your maintenance activities, see 13.2 Maintenance Log on page 47.

10.7 Reconditioning

Reconditioning can eliminate or reduce capacity losses of a battery system. It is carried out by repeatedly discharging/charging of the battery system with constant current.



Danger!

Danger of explosion due to formation of oxyhydrogen gas!

When the cells are charged, water is decomposed and a hydrogen-oxygen-gas mixture (oxyhydrogen gas) is formed, which readily explodes with low energy input.

Keep any source ignition away from the battery system:

- Open flames or fire
- Smoking
- Glowing embers
- Flying sparks during grinding work
- Electrical sparks caused by switches or fuses
- Hot surfaces with temperature above 300 °C
- Electrostatic discharges

Work with electrically insulated tools that do not create sparks.

Ground yourself when working directly on the battery system.

Make sure that there is adequate ventilation in accordance with IEC 62485-2, so that the potential explosive gas mixture is discharged.



Warning!

Contact with the electrolyte can happen when measuring the electrolyte level. It can cause severe chemical burns to the skin and severe damage to the eyes.



While working on batteries wear face protection (impact resistant visor according to EN 166 class F or similar), protective eye-glasses, protective gloves and clothing.

Observe accident prevention regulations as well as EN 50110-1 and IEC 62485-2.



Attention!

Ensure that the battery room or cabinet has an adequate ventilation. The ventilation has to keep the hydrogen concentration below the threshold of 4 % by volume during battery charging, in accordance with IEC 62485-2.



Precondition

Check the electrolyte level in each cell:

The electrolyte levels must be higher than the middle between minimum and maximum. Fill up the electrolyte levels with distilled water to the middle between minimum and maximum if necessary. For instructions, refer to 10.2 Checking the Electrolyte Levels on page 34.

For reconditioning, the battery is supplied with an electric charge of 1.5 C_n, where relatively high cell voltages can arise while charging (up to 1.9 V).

1. Remove the plugs at each grid | power FNC®-cell.



Valid for grid | power FNC® VR-cells

Remove a VR plug carefully. It is recommended to use the HOPPECKE plug opener (Mat. No. 4142500125).

Alternatively use a small, slot screwdriver. Grab the plug with your hand and slowly twist and vertically pull out the plug from the cell opening.

Wear personal protective equipment because grid | power FNC® VR-cells operate under pressure. Removing a VR plug can release electrolyte spray.

2. Remove the insulation profiles.

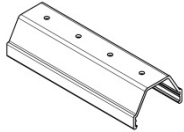

3. Measure the voltages of the individual cells using a digital multimeter and note the values in the maintenance log. The open circuit voltage of a fully charged, non-defective cell at 20 °C is ≥ 1.3 V.



The individual cell voltages should not vary by more than ± 50 mV from the mean of all cell voltages. If the open circuit voltage of a cell is < 1.2 V, contact HOPPECKE service.

4. It is recommended to insert a gas venting tube on each grid | power FNC®-cell, (HOPPECKE Mat. No.: 4143180100). This reduces the contamination by electrolyte.

5. Discharge the battery system by using a charging/discharging device with nominal current I₅, until the voltage of the battery system has dropped to 1.0 V per cell in the arithmetic middle (e. g., battery system with 54 cells → 54 V).

6. Allow the battery system to rest open circuit for at least 8 hours, preferably overnight.

7. Measure the temperature of the battery system by inserting a suitable glass thermometer. The cell to be measured should be installed in the centre of the system, in order to capture the warmest possible spot of the system. Record the measured value.

8. Charge the battery system using a constant current of I₅ for 7.5 hours.



Attention!

The battery system must not exceed a temperature of 45 °C during charging.

Once a temperature of 45 °C is reached, stop the charging process.

Make a note of the remaining charging time.

Only continue charging when the cell temperature has dropped below 25 °C.

Complete the remaining charging time of 7.5 hours after the battery system has cooled.

Should the battery again reach a temperature of 45 °C before the charging time of 7.5 hours is completed, interrupt the charging process again, and repeat as necessary.

9. Allow the battery system to rest for at least 2 hours.

10. Discharge the battery system by using a charging/discharging device with nominal current I₅, until the voltage of the battery system has dropped to 1.0 V per cell and measure the time elapsed. This is the capacity test.



If the battery system takes 5 hours to drop 1.0 V per grid | power FNC®-cell its capacity is 100 %:

- 5 hours → 100 %

- 4.5 hours → 90 %

- 4 hours → 80 %

- 3 hours → 60 %

...

11. Allow the battery system to rest for at least 8 hours, preferably overnight. If the discharge time is ≤ 4.5 hours, repeat the process from point 8.



If the discharge time is still ≤ 4.5 hours after 5 repetitions of this procedure, contact HOPPECKE service.

12. Charge the battery system using a constant current of I₅ for 7.5 hours.



Attention!

The battery system must not exceed a temperature of 45 °C during charging.

Once a temperature of 45 °C is reached, stop the charging process.

Make a note of the remaining charging time.

Only continue charging when the cell temperature has dropped below 25 °C.

Complete the remaining charging time of 7.5 hours after the battery system has cooled.

Should the battery again reach a temperature of 45 °C before the charging time of 7.5 hours is completed, interrupt the charging process again, and repeat as necessary.

13. Allow the battery system to rest for at least 8 hours, preferably overnight.

14. Remove the gas venting tubes.

15. Thoroughly remove any contamination on the battery system with a soft, damp cloth with water.

16. Refill the electrolyte level with distilled water to the maximum level, see 10.6 Fill up the Electrolyte Level with Distilled Water on page 37.

17. Remount the plugs to the FNC®-cells.

18. Measure the voltages of the individual cells using a digital multimeter.



If the individual cell voltages vary by more than ± 50 mV from the mean of all cell voltages, contact HOPPECKE service.

19. Clean the battery system if necessary.

20. Mount the insulation profiles.

21. Measure the insulation resistance of the battery system, see 10.4 Testing the Insulation Resistance on page 36.

22. Keep a log of your maintenance activities, see 13.2 Maintenance Log on page 47.

11 Troubleshooting

11.1 Over Consumption of Distilled Water

During charging, electrolysis decomposes the water of the electrolyte into the gases $2H_2 + O_2$. This leads to a lowering of the electrolyte level. The volume of decomposed water depends on charging voltage, charging time per day and temperature.

If you detect an over consumption of distilled water, proceed as follows:

Possible Cause	Remedy
Charging voltage is too high	Check the charger
Dispersion of the individual cell voltages	See next chapter

11.2. Dispersion of the Individual Cell Voltages

If you detect that the individual cell voltages show variations of more than ± 50 mV from the mean of all cell voltages, proceed as follows:

Possible Cause	Remedy
Variations in cell temperature	Check the ventilation
Differences in the electrolyte density of the cells	The equalization must be performed by HOPPECKE service
Plate short-circuits in one or more cells	Measure the individual cell voltages; Change the defect cells
Various charge states of the cells	Run a reconditioning charge
Insulation resistance is too low	See 11.4 Insulation Resistance is Low on page 43

11.3 Available Battery Capacity is Low

Insufficient capacity may be due to the following causes:

Possible Cause	Remedy
Boost charging process is too short	Run a reconditioning charge
Electrolyte levels are below minimum level	Correct the electrolyte level
Loose or oxidised terminals	Control all connections, change connectors if necessary (use new spring washers)
Insulation resistance is too low	See 11.4 Insulation Resistance is Low on page 43

11.4 Insulation Resistance is Low

Definition:

Minimum insulation resistance = $100 \Omega \times 1.2 V \times \text{number of FNC}^\circ\text{-cells}$

In case of an insulation fault, leakage currents may reduce the available capacity of the battery. This runs the risk of giving rise to different cell voltage. Regular cleaning can prevent these leakage currents and different cell voltages.

Possible Cause	Remedy
Contamination	Cleaning
Leaks in a cell	Correct the reason of the leakage; possibly exchange the cell

11.5 Battery Voltage not Measureable

If you cannot measure a voltage, proceed as follows:

Possible Cause	Remedy
A fuse has tripped	Search for the fault; switch on/exchange the fuse
Broken cables	Change the cable
Defect connectors	Change the connector (use new spring washers)

12 Disassembly, Disposal and Recycling



Danger!

Caused by:

- Voltages
- Electric shock

Before starting to disassemble the battery, disconnect any supply and load cables (fuses).

Based on the content of cadmium and caustic potassium, grid | power FNC[®]-batteries must not be disposed of at the end of their service life with household waste.

Check the local regulations and codes regarding storage of waste batteries.



Note

Old batteries bearing this sign are recyclable economic goods and must be returned via the recycling process.

You can use the HOPPECKE recycling system. The old batteries are picked up and returned to the recycling system. Contact HOPPECKE Service for further information.



Note

Dispose of nickel-cadmium batteries, which are not returned to the recycling process, as special waste in compliance with all regulations.

13 Appendix

13.1 Commissioning Record

A record should be made during commissioning of the battery:

Customer:
Order No.:
Where installed:
Supplier:

Battery No.:
Cell type:
No. of cells:
Capacity [Ah]:

Charging voltage (tick and fill out):

<input type="checkbox"/> Charging with constant current I_s	<input type="checkbox"/> Charging with constant current and constant voltage Constant current [A]: Maximum voltage [V]:
--	--

Battery voltages:

	Start of charging	End of charging
Open-circuit voltage [V]		
Charging voltage [V]		

Charging current:

	Start of charging	End of charging
Charger current [A]		

Temperatures:

	Start of charging	End of charging
Ambient [°C]		
Electrolyte [°C] of pilot cell number:		

Loading time:

	from	to
Date		
Time [h]		

Commissioning confirmation:

	Date	Signature
Commissioning carried out by		
Acceptance (supplier) carried out by		
Acceptance (customer) carried out by		

13.2.1 Six-monthly Maintenance Interval

13.2.1.1 Visual Inspection and Checking Electrolyte Level

Interval (years)	Done (mark with a cross)	Date	Inspector (name)
0.5			
1			
1.5			
2			
2.5			
3			
3.5			
4			
4.5			
5			
5.5			
6			
6.5			
7			
7.5			
8			
8.5			
9			
9.5			
10			
10.5			
11			
11.5			
12			
12.5			
13			
13.5			
14			
14.5			

13.2.1.2 Measuring battery system voltage

Interval (years)	Measured value in Volt	Date	Inspector (name)
0.5			
1			
1.5			
2			
2.5			
3			
3.5			
4			
4.5			
5			
5.5			
6			
6.5			
7			
7.5			
8			
8.5			
9			
9.5			
10			
10.5			
11			
11.5			
12			
12.5			
13			
13.5			
14			
14.5			

13.2.2 Annual Maintenance Interval

13.2.2.1 Cleaning the battery system

Interval (years)	Done (mark with a cross)	Date	Inspector (name)
1			
2			
3			
4			
5			
6			
7			
8			
9			
10			
11			
12			
13			
14			

13.2.2.2 Insulation testing

Interval (years)	Measured value in Ohm	Date	Inspector (name)
1			
2			
3			
4			
5			
6			
7			
8			
9			
10			
11			
12			
13			
14			

13.2.2.3 Filling up distilled water

Interval (years)	Done (mark with a cross)	Date	Inspector (name)
1			
2			
3			
4			
5			
6			
7			
8			
9			
10			
11			
12			
13			
14			

13.2.3 Maintenance Interval every 5 years

13.2.3.1 Reconditioning

Interval (years)	Done (mark with a cross)	Date	Inspector (name)
5			
10			

13.2.3.2 Measuring of Single Cell Voltages

Interval (years)	Cell number	Measured value in Volt	Cell number	Measured value in Volt	Cell number	Measured value in Volt
5						

Date: _____ Inspector: _____

Hint: Reproduce this page according to the number of cells of your battery system.









Interval (years)	Cell number	Measured value in Volt	Cell number	Measured value in Volt	Cell number	Measured value in Volt
10						

Date: _____ Inspector: _____

Hint: Reproduce this page according to the number of cells of your battery system.

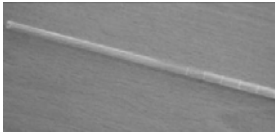
13.3 Useful tools

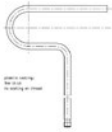
In the following you find a list with tools which helps you in case of maintenance and service:

Tool	Description
	Voltmeter/multimeter (illustration shows an example)
	Insulation tester (illustration shows an example)
	External charge/discharge unit (illustration shows an example)
	Waterfilling cart 230 V (HOPPECKE Mat. No.: 4147000210) 115 V (HOPPECKE Mat. No.: 4147000215)
	Glass tube for measuring (HOPPECKE Mat. No.: 4144140010)
	Gas venting tube (HOPPECKE Mat. No.: 4143180100)
	Cell lifter Format 3, 4, 5: M10 (HOPPECKE Mat. No.: 4141900003) Format 1, 2: M8 (HOPPECKE Mat. No.: 4141900002)
	Plug opener for cells with valve plug (VR plug) (HOPPECKE Mat. No.: 4142500125)

Installation, commissioning and operating instructions

for stationary Fibre Nickel Cadmium Batteries grid | power FNC®